

# Taxonomic revision of Taiwanese and Japanese *Cyrtophora* spiders hitherto identified with *C. moluccensis* (Arachnida: Araneae), using molecular and morphological data

Akio Tanikawa<sup>1)</sup>, Yung-Hau Chang<sup>2)</sup> & I-Min, Tso<sup>3)</sup>

<sup>1)</sup> Laboratory of Biodiversity Science, School of Agriculture and Life Sciences, The University of Tokyo, 1-1-1, Yayoi, Bunkyo-ku, Tokyo, 113-8657 Japan

E-mail: dp7a-tkw@j.asahi-net.or.jp

<sup>2)</sup> Hua Hsing High School, ShiLin Dist., Taipei City, Taiwan

E-mail: yunghauc@gmail.com

<sup>3)</sup> Department of Life Science, Tunghai University, Taichung 407, Taiwan

E-mail: spider@thu.edu.tw

---

**Abstract** — The Taiwanese and Japanese spiders which have been identified with *Cyrtophora moluccensis* (Doeshall 1857) are taxonomically revised. Three color morphs, yellow-, green-, and red-types, show their own discrete monophyletic clades in the phylogenetic tree inferred by Neighbor Joining method using the partial sequences of mt-16S-rRNA genes. P-distances within group means are 0.2% in the yellow-type, 0.1% in the green-type, and 0% in the red-type. P-distances between group means are 18.8% between yellow- and green-types, 19.4% between yellow- and red-types, 10% between green- and red-types. These three color morphs can be separated also by the shapes of epigynum and male palp. Consequently we recognize them as three independent nominal species and determined the yellow-type as *C. cylindroides* (Walckenaer 1842), the green-type as *C. moluccensis* (Doleschall 1857), and the red-type as *C. ikomosanensis* (Bösenberg & Strand 1906).

**Key words** — taxonomy, revival, *Cyrtophora moluccensis*, *Cyrtophora ikomosanensis*, *Cyrtophora cylindroides*.

---

## Introduction

Spiders with wide distribution ranges or remarkable color variations often have many junior synonyms. In contrast, some independent species belonging to a flock of several species showing enormous variations as a whole sometimes have been erroneously synonymized. (e.g. *Dolomedes sulfureus*, Tanikawa & Miyashita 2008). *Cyrtophora moluccensis* (Doleschall 1857), first described from Amboina, is such an example. This species is widespread from India to Japan and to Australia (Platnick 2010) and known to have a remarkable color variation and have many junior synonyms (cf. synonym list in taxonomic part). *Cyrtophora ikomosanensis* (Bösenberg & Strand 1906) and *Suzumia orientalis* Kishida in Yuhara 1931 described from Japan also have been synonymized with *C. moluccensis* (Yaginuma 1958, 1968b). Recently we recognized three color morphs, yellow-, green-, and red-types, among the specimens collected from Taiwan (Figs. 1–3). We examined the partial sequences of mt-DNA 16S-rRNA genes, and morphological features of Taiwanese and Japanese specimens to determine whether they are color morphs of the same species or independent nominal species.

Following abbreviations are used in this paper: AT, Akio Tanikawa; MOA, median ocular area; NSMT, National Museum of Nature and Science, Tokyo; THU, Tunghai University.

## Materials and methods

Molecular study.

*DNA extraction, polymerase chain reaction and sequencing.* A total of 12 specimens collected from Taiwan and Japan (Table 1) were used for molecular work (6, 4, and 2 specimens for the red-, green-, and yellow-types, respectively). They were preserved in 75% ethanol and genomic DNA was extracted from muscle of legs using Puregene DNA isolation kit (Gentra Systems, Inc., Minneapolis, MN, USA). The mitochondrial 16S-rRNA gene partial sequences were amplified using the primer combination: forward AGA GTT TGA TCC TGG CTC AG, reverse ACG GCT ACC TTG TTA CGA CTT. The reactants were initially denatured for 3 min at 95°C, proceeded with 30 cycles of 60 sec at 95°C, 60 sec at 50°C, 60 sec at 72°C and then the final extension at 72°C for 10 min. PCR products were assayed by electrophoresis on 1.2% agarose minigel visualized under UV light after ethidium bromide staining. The

**Table 1.** Haplotypes and DDBJ/EMBL/GenBank accession numbers of *Cyrtophora* specimens used for DNA analysis.

Type	N	Locality	Haplotype	Accession No.
Yellow	1	Tiensiung, Taiwan	CCY01	AB541017
Yellow	1	Nanjenshan, Taiwan	CCY02	AB541018
Green	2	Nanjenshan, Taiwan	CML01	AB541019
Green	1	Fushan, Taiwan	CML01	AB541019
Green	1	Tiensiung, Taiwan	CML02	AB541020
Red	4	Fushan, Taiwan	CIK01	AB541021
Red	1	Amami-ôshima Is., Japan	CIK01	AB541021
Red	1	Okinawajima Is., Japan	CIK01	AB541021

target DNA fragments were isolated and purified by the Gel/PCR DNA Fragments Extraction Kit (Geneaid, Taiwan). The purified PCR products were sequenced using the BigDye terminator cycle sequencing kit and analysed on ABI 3100 or 3730 automated DNA sequencer (Applied Biosystems, Foster City, CA).

**Data analyses.** Chromatograms and contiguous alignments were edited using Seqman version 4.00 (DNASTar Inc., Madison, WI). All sequences were aligned via Clustal W program (Thompson et al. 1994) in MEGA version 4.0 (Tamura et al. 2007). The phylogenetic trees were constructed using MEGA version 4.0 (Tamura et al. 2007) by Neighbor Joining method.

**Morphological study.**

Many specimens from Taiwan, Japan and other regions were used for morphological study. They were preserved in 75% ethanol and their morphological features were examined under stereo microscope. In particular, shapes of epigynums and male palps were compared.

## Results

**Molecular analysis.**

We obtained 490 to 493 bp of mt-16S-rRNA partial sequence from the specimens used. The accession numbers of DDBJ/EMBL/GenBank are shown in table 1. The bootstrap consensus tree inferred from 1000 bootstrap replicates of Neighbor Joining is shown in Fig. 4. Topology is comprised of three monophyletic clades, that is, green-type clade, red-type clade, and yellow-type clade. P-distances (the number of nucleotide difference/total number of nucleotides) within group means are 0.2% in yellow-type, 0.1% in green-type, and 0% in red-type. P-distances between group means are 18.8% between yellow-type and green-type, 19.4% between yellow-type and red-type, 10% between green-type and red-type.

**Morphological analysis.**

The yellow-type specimens were separable from the green- and the red-type specimens by general appearance (Fig. 1), shape of epigynum (Figs. 5–6), and shape of male palpal organ (Fig. 7).

The green-type and the red-type specimens closely resemble each other, but the following differences were recognized. 1) In lateral view, median septum of epigynum is more curved in green-type (Figs. 9–11) than red-type (Figs. 14–16). 2) Male carapace is uniformly reddish brown in

green-type (Fig. 19), but brown with a pair of black markings in red-type (Fig. 20). 3) The median apophysis of male palp is thicker in red-type (Fig. 17) than green-type (Fig. 12).

## Conclusion

We conclude that three types of *C. moluccensis* from Taiwan and Japan are the independent nominal species, because 1) the partial sequences of mt-16S-rRNA genes showed clear differences among three types, and each of them formed a discrete monophyletic clade, 2) they can be separated by the morphological features, 3) they are sympatric in Taiwan (red-type and green-type are sympatric also in Iriomotejima Is. near Taiwan).

We identified the yellow-type specimens as *Cyrtophora cylindroides* (Walckenaer 1842) by the general appearance and the shape of epigynum and the shape of male palpal organ (Figs. 1, 5–7; Chrysanthus 1959, Figs. 6, 10; Chrysanthus 1960, figs. 1–2). Although the type specimen of *Cyrtophora moluccensis* was unavailable to us, we were able to examine the topotypical specimens of the species, which led us to conclude that the green-type is *C. moluccensis* (Doleschall 1857). We identified the red-type specimens as *C. ikomosanensis* (Bösenberg & Strand 1906) which was described from Japan (Figs. 13–17; Bösenberg & Strand 1906, pl. 11, Fig. 224) and has long been synonymized with *C. moluccensis* since Yaginuma's treatment (Yaginuma 1986b).

## Taxonomy

Genus *Cyrtophora* Simon 1864  
*Cyrtophora cylindroides* (Walckenaer 1842)  
 [Japanese name: Tsutsu-suzumigumo]  
 (Figs. 1, 5–7)

*Epeira cylindroides* Walckenaer 1842, p. 136.

*Cyrtophora cylindroides*: Pocock 1898, p. 462; Chrysanthus 1959, p. 200, figs. 6, 10, 25; Chrysanthus 1960, p. 25, figs. 1–2; Yin et al. 1990, p. 67, figs. 169–170; Yin et al. 1997, p. 280, figs. 190a–c; Song, Zhu & Chen 1999, p. 279, figs. 164A, D, 165C.

Specimens examined. TAIWAN: 1♀, 15–VIII–2002 (THU-Ar 2010–001), 1♀, 20–VIII–2002 (THU-Ar 2010–002), Nanjenshan, Pingtung County, Y.-H. Chang leg.

SINGAPORE: 1♀, 5-VIII-1995, Bukit Timah, H. Nakajima leg. (NSMT-Ar 8676). THAILAND: 1♀, II-2006, Ban Khum Mae Sakud, Mae Hong Son Province, K. & R. Phongpiyamat & M. Nishimura leg. (NSMT-Ar 8677). 1♂, Khuan, Khao Wang Forest Park, Hat Yai District, Songkhla Province, 6-I-2009, B. Ponksee leg.

*Description.* Measurements. Based on the 1♀ from Taiwan (THU-Ar 2010-002) and 1♂ from Thailand, measurements in parentheses indicate the range among specimens, ♀/♂, in mm. Body 17.50 (13.19-17.50)/3.22 long. Carapace 7.67 (5.59-7.67)/1.69 long; 6.00 (4.21-6.00)/1.29 wide. Length of legs [tarsus + metatarsus + tibia + patella + femur = total]: I, 2.40 + 8.10 + 6.90 + 3.30 + 9.80 = 30.50/0.78 + 1.47 + 1.40 + 0.61 + 1.64 = 5.90; II, 1.80 + 5.85 + 4.95 + 0.60 + 7.35 = 20.55/0.71 + 1.33 + 1.16 + 0.60 + 1.56 + 5.36; III, 1.35 + 3.40 + 2.70 + 1.90 + 4.65 = 14.00/0.53 + 0.73 + 0.62 + 0.38 + 1.00 = 3.26; IV, 1.50 + 6.10 + 4.65 + 2.65 + 7.30 = 22.20/0.62 + 1.31 + 1.00 + 0.49 + 1.49 = 4.91. Abdomen 10.88 (8.17-10.88)/1.65 long, 6.75 (5.42-6.75)/1.31 wide.

Female and male. Carapace longer than wide [length/

width 1.28 (1.23-1.33)/1.31]. MOA longer than wide (or almost as long as wide) [1.26 (0.98-1.26)/1.04], same width in front and behind or longer in front than behind [anterior width/posterior width 1.00 (0.79-1.01/1.19)]. Labium wider than long [length/width 0.76 (0.63-0.76)/0.50]. Sternum slightly longer than wide [length/width 1.10/1.16]. Length of leg I/length of carapace 3.98 (3.97-4.27)/3.49. Male palp: embolus, long and semicircle (Fig. 7, arrow); after mating, broken and left in epigynum (Fig. 6, arrow). Abdomen longer than wide [length/width 1.61 (1.51-1.61)/1.26], anteriorly with a pair of tubercles (Fig. 1). Epigynum with a pair of depressions and two pairs of semicycle grooves (Fig. 6); after mating, embolus (Fig. 7, arrow) remained in outer groove of copulatory opening (Fig. 6, arrow).

*Coloration and markings.* Female. Carapace light brown with dark colored borders. Abdomen pale yellow mottled with white and dark brown (Fig. 1). Male. Carapace dark brown, center part lighter. Abdomen dark brown with a pair of white markings.

*Distribution.* China, Taiwan, Vietnam, Singapore,

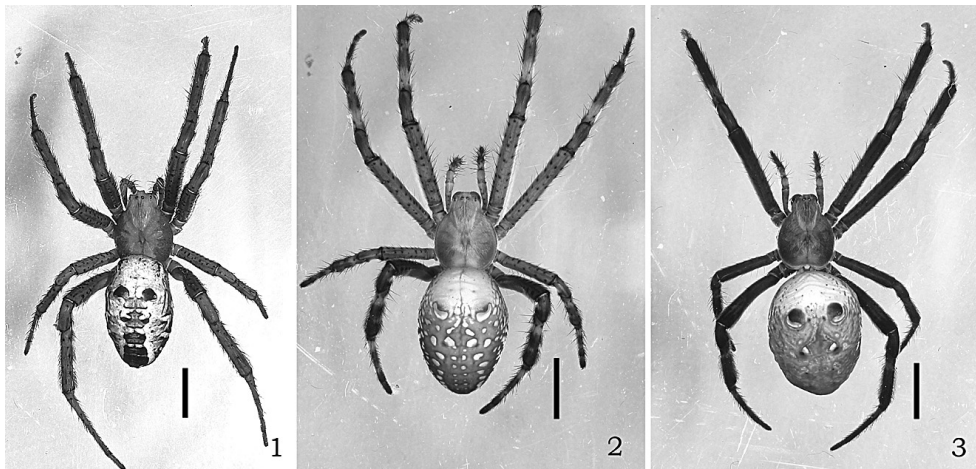

**Figs. 1-3.** Hbitus of three color morphs. 1, Yellow-type (Nanjenshan, Taiwan); 2, Green-type (Chipen, Taiwan); 3, Red-type (Fushan, Taiwan). Scales: 5 mm.

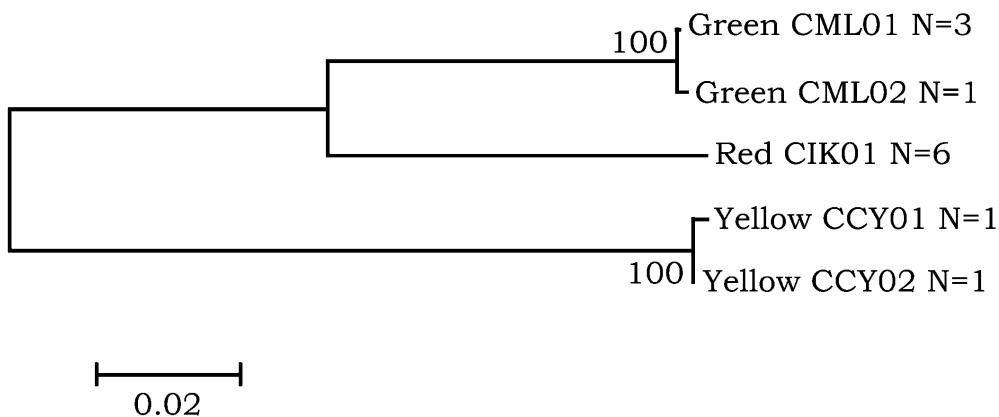

**Fig. 4.** The unrooted bootstrap consensus tree inferred from 1000 bootstrap replicates of Neighbor Joining method. Scalebar shows substitution per site.

Thailand, Solomon Islands, New Guinea Island.

*Remarks.* The present species can be distinguished from *C. moluccensis* and *C. ikomosanensis* by the general appearance (Figs. 1–3, 17–25) as well as the shapes of genital organs of both sexes (Figs. 5–7, 8–16). The conspicuous features are: long and semicircle embolus of male palp (Fig. 7, arrow) and two pairs of semicircle grooves of epigynum in posterior view (Fig. 6).

*Cyrtophora moluccensis* (Doleschall 1857)  
[Japanese name: Hoshi-suzumigumo]  
(Figs. 2, 8–12, 17–19)

*Epeira moluccensis* Doleschall 1857, p. 418. [Female type specimen from Amboina, not found]

*Epeira maritima* Keyserling 1865, p. 813, pl. 18, figs. 22–23.

*Epeira hieroglyphica* L. Koch 1871, p. 89, pl. 7, fig. 8. [Male holotype from Samoa, preserved in Naturhistorische Museum, Wien, examined]

*Cyrtophora moluccensis*: Simon 1895, p. 770, fig. 846; Kulczyński 1910, p. 394, pl. 17, fig. 5; Yaginuma 1958, p. 14, figs. 2F–H (specimens from Samoa); Chrysanthus 1959, p. 199, figs. 1, 9, 30; Chrysanthus 1971, p. 19, figs. 31–33; Tikader 1982, p. 172, figs. 326–330; Davies 1988, p. 320, fig. 42; Koh 1991, p. 179, figs. 15–17; Yin et al. 1997, p. 285, figs. 195a–g; Song, Zhu & Chen 1999, p. 280, figs. 164I, L. S; Chen 2001, p. 72; Li et al. 2002, p. 182; Tanikawa 2003, pp. 11, 87, fig. 215b (in part).

*Araneus moluccensis*: Pocock 1897, p. 599, pl. 25, fig. 9.

*Cyrtophora simoni* Rainbow 1898, p. 337, pl. 7, fig. 4.

*Cyrtophora albopunctata* Rainbow 1898, p. 339, pl. 7, fig. 5.

*Suzumia orientalis*: Kayashima 1943, p. 54, fig. 2.

*Suzumia moluccensis*: Nakatsudi 1943a, p. 160, fig. 1 in pl. 23.

*Cyrtophora ikomosanensis*: Yaginuma 1958, p. 14, fig. 2D (specimen from Taiwan); Yaginuma 1960, fig. 158 in pl. 28 (right lower figure, specimen from Taiwan); Yaginuma 1968, fig. 158 in pl. 28 (right lower figure, specimen from Taiwan).

*Specimens examined.* Topotypical specimens. 1♀1♂, Ambon Is., labeled as “Amboina Doleschall leg 1858, Acqu. Nr. 1858. I. 12, E. Reimoser det. D. T. Corey rev. 1991” (Naturhistorisches Museum, Wien, 20632).

Other specimens examined. JAPAN. 2♂, Otomi, 27–VI–2004 (NSMT-Ar 8678–8979), 1♀, 28–XII–1987 (NSMT-Ar 8980), 2♀, 30–XII–1988 (NSMT-Ar 8981), 1♂, 6–VI–2007 (NSMT-Ar 8982), Urauchi, Iriomote-jima Is., Okinawa Pref., AT leg. TAIWAN. 1♀1♂, Tien Hsiang, Hualien County, 11–VIII–2002, Y.-H. Chang leg. (THU-Ar 2010–003). Nanshanhsi, 4♀, Nantou County, 28–XII–1994, T. Kimura leg. (1♀: NSMT-Ar 8983). 1♀, Chihpen, Taitung County, 13–VIII–2002, Y.-H. Chang leg. (THU-Ar 2010–004). MARIANA ISLANDS. 2♀, Anatahan Is. 11–V–1992, T. Kurozumi & S. Miyano leg. (NSMT-Ar 8984). Gauam Is. 1♂, 19–X–1995, K. Ogata leg. (NSMT-Ar 8985), 2♂, 17–III–2002, T. Kimura leg. SAMOA. 1♂ labeled as “Ovalau (Samoa) Museum Godeffrog Kauf, Acqu. Nr. 1882. II. 73,

det L.Koch? *Epeira hieroglyphica* SYNTYPES? D. T. Corey rev.” (Naturhistorisches Museum, Wien, 20629). AUSTRALIA. 2♀, Cairns, 2–I–1993, AT leg. (1♀: NSMT-Ar 8986). PAPUA NEW GUINEA. 1♀, Baiyer River near Mount Hagen, 31–VII–2003, AT leg. (NSMT-Ar 8987). INDONESIA. 1♀, Celebes (National Museum of Natural History Naturalis, Leiden, 928 5526); 9♀, Wamena, 3–VIII–1982 (1♀: NSMT-Ar 8988), 6♀, Jayapura, 5–VIII–1982, Papua Barat, AT leg. SINGAPORE. 1♀, XII–1995, H. Nakajima leg.

*Description.* Measurements. Based on 1♀ from Anatahan Is. (NSMT-Ar 8984) and 1♂ from Iriomotejima Is. (NSMT-Ar 8678), measurements in parentheses indicate the range among specimens, ♀/♂, in mm. Body 19.88 (10.25–23.00)/3.28 (3.28–3.84) long. Carapace 9.10 (4.65–9.10)/1.53 (1.53–1.88) long; 7.10 (3.60–7.10)/1.22 (1.22–1.53) wide. Length of legs [tarsus + metatarsus + tibia + patella + femur = total]: I, 2.75 + 11.00 + 9.13 + 4.00 + 12.38 = 39.26/0.75 + 1.36 + 1.33 + 0.56 + 1.73 = 5.73; II, 2.75 + 9.75 + 8.19 + 4.00 + 11.88 = 36.57/0.72 + 1.20 + 1.11 + 0.55 + 1.60 = 5.18; III, 2.00 + 5.75 + 3.88 + 2.81 + 7.00 = 21.44/0.49 + 0.66 + 0.53 + 0.39 + 0.96 = 3.03; IV, 2.25 + 9.25 + 6.88 + 4.00 + 11.25 = 33.63/0.56 + 1.15 + 0.90 + 0.51 + 1.46 = 4.58. Abdomen 13.00 (7.08–16.50)/1.86 (1.78–2.13) long, 9.25 (4.77–10.38)/1.30 (1.22–1.44) wide.

Female and male. Carapace longer than wide [length/width 1.28 (1.27–1.30)/1.26 (1.22–1.26)]. MOA longer than wide in female [length/width 1.27 (1.27–1.30)], almost as long as wide in male [length/width 1.02 (0.96–1.02)], anterior width and posterior width almost same in female [anterior width/posterior width 1.00 (1.00–1.10)], wider in front than behind in male [anterior width/posterior width 1.25 (1.19–1.28)]. Fung furrow of chelicera with 4 promarginal and 3 (3–4)/3 retromarginal teeth. Labium wider than long [length/width 0.76 (0.58–0.76)/0.63 (0.55–0.63)]. Sternum slightly longer than wide [length/width 1.12 (1.07–1.13)/1.11 (1.02–1.11)]. Length of leg I/length of carapace 4.31 (4.15–4.54)/3.75 (3.75–3.87). Median apophysis of male palp thin (Fig. 12, arrow). Abdomen longer than wide [length/width 1.41 (1.41–1.61)/1.43 (1.34–1.52)], anteriorly with a pair of tubercles (Figs. 2, 17–18). Female genitalia: median septum much curved in lateral view (Figs. 9–11).

Coloration and markings. Female. Carapace dark brown with many white pubescences, abdomen dark brown mottled with white (Figs. 2, 17–18). Male. Carapace uniformly reddish brown, abdomen green with white markings (Fig. 19).

*Distribution.* Japan (Iriomotejima Is.), Taiwan, widespread in South East Asia, and Mariana Islands to Australia.

*Remarks.* The present species can be separated from *C. ikomosanensis* by the following points. 1) In lateral view, median septum is more curved (Figs. 9–11) than *ikomosanensis* (Figs. 14–16). 2) Male carapace is uniformly reddish brown (Fig. 19), but brown with a pair of black markings in *ikomosanensis* (Fig. 20). 3) Median apophysis of male palp is thinner (Fig. 12, arrow) than *ikomosanensis* (Fig. 17, arrow).

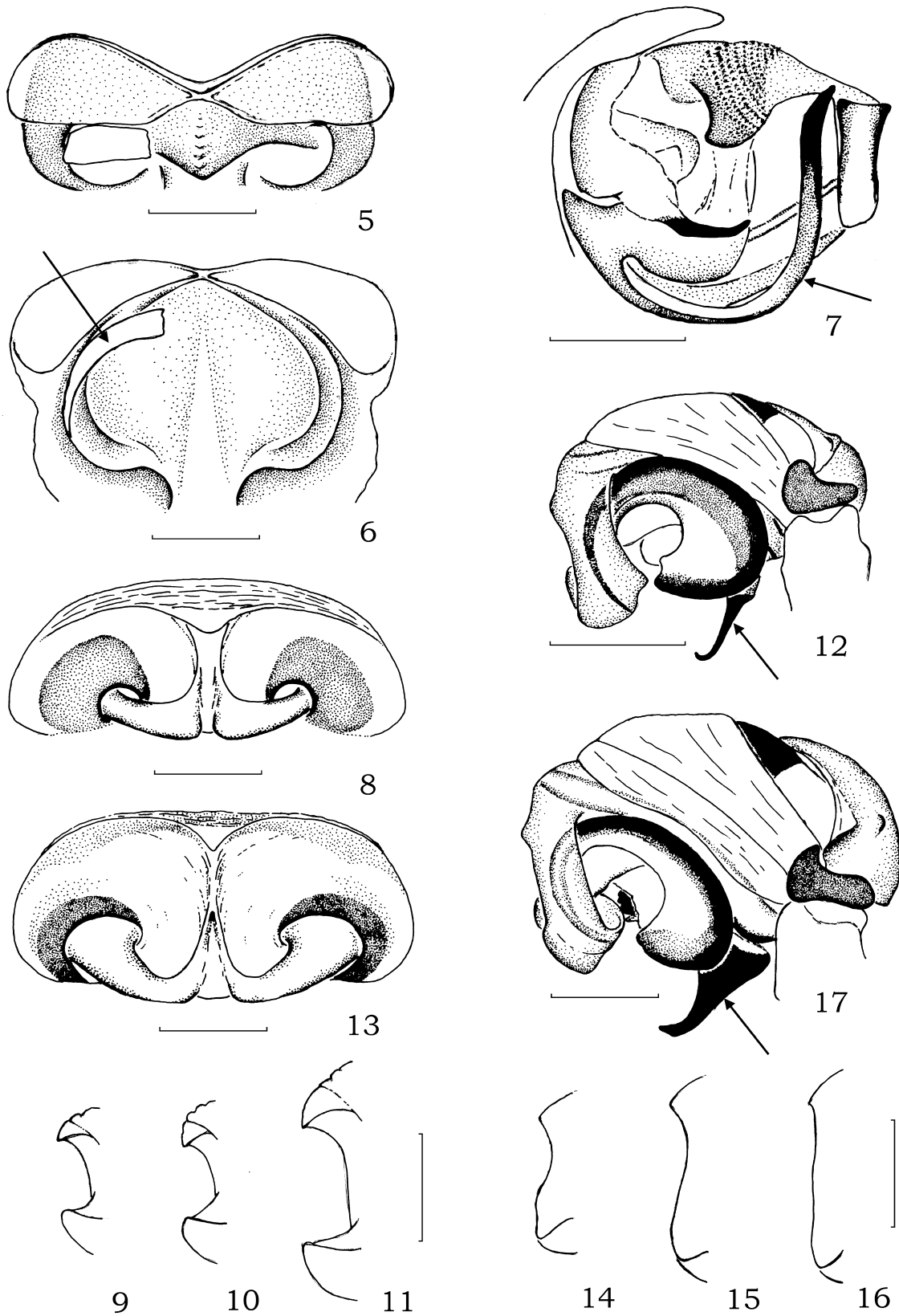

**Figs. 5-17.** Genital organ. 5-7, Yellow-type, *Cyrtophora cylindroides*; 8-12, Green-type, *Cyrtophora moluccensis*; 13-17, Red-type, *Cyrtophora ikomosanensis*. — 5, 8, 13, epigynum, ventral view; 6, same, posterior view; 7, male palp, prolateral view; 12, 17, same, retrolateral view; 9-11, 14-16, median septum of epigynum, lateral view. (5-6, THU-Ar 2010-002, 8-9, THU-Ar 2010-003, 10, NSMT-Ar 8680, 11, NSMT-Ar 8688, 12, NSMT-Ar 8678, 13-14, NSMT-Ar 8692, 15, NSMT-Ar 8698, 16, NSMT-Ar 8699, 17, NSMT-Ar 8693; Scales: 0.25 mm.

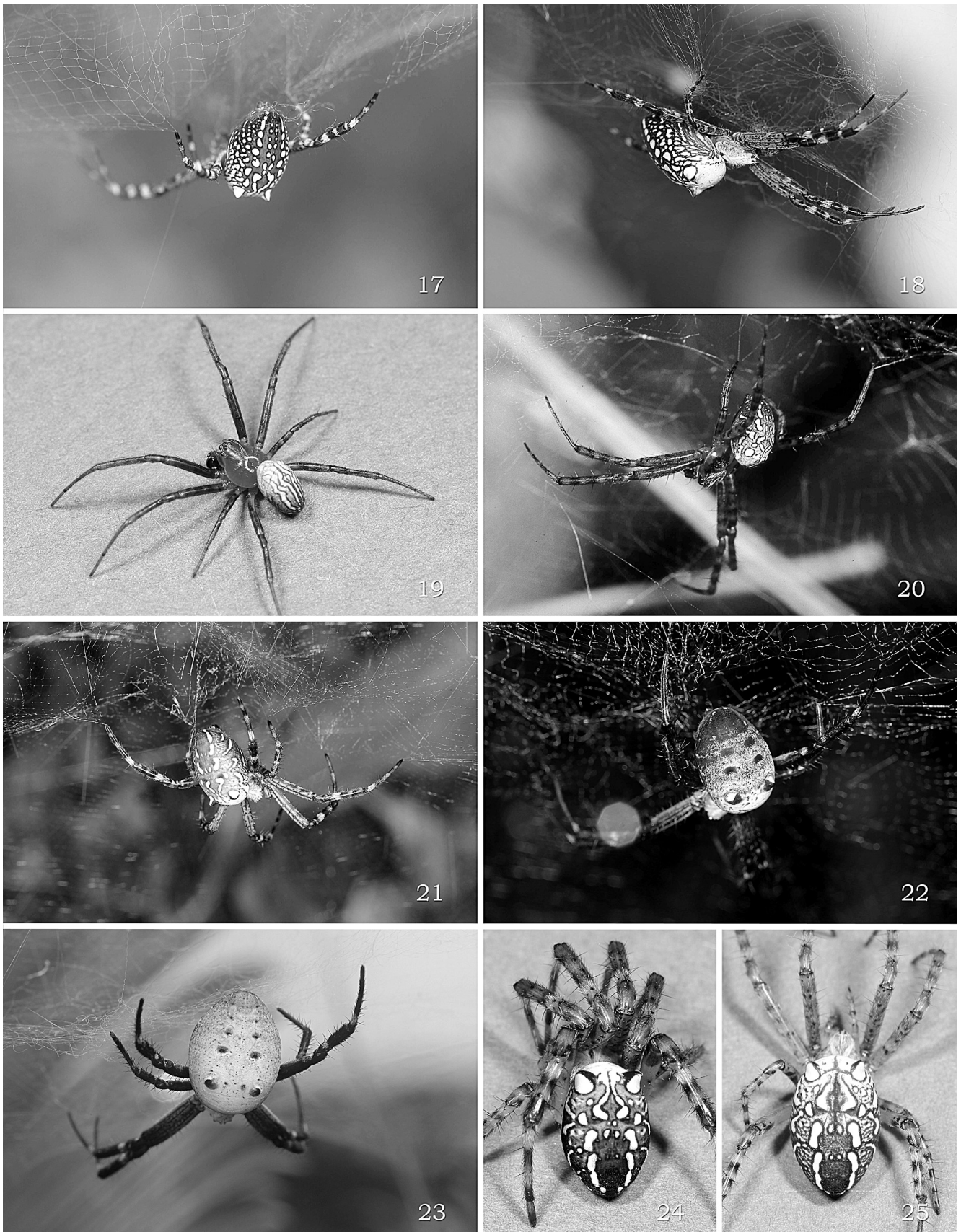

**Figs. 17–25.** Habitus. 17–19, *Cyrtophora moluccensis*; 20–25, *Cyrtophora ikomosanensis*; — 17–18, female (Iriomotejima Is.); 19–20, male (Iriomotejima Is.); 21, 24–25, juvenile (Okinawajima Is.); 22–23, female (22, Amami-ōshima Is., 23, Tokunoshima Is.).

*Cyrtophora ikomosanensis* (Bösenberg & Strand 1906)  
[Japanese name: Suzumigumo]  
(Figs. 3, 13–17, 20–25)

*Aranea ikomosanensis* Bösenberg & Strand 1906, p. 234, pl.11, fig. 224 [female holotype from "Ikomosan, Yamato ("Ikomosan" is probably a misspelling of "Mt. Ikomosan" in Nara Prefecture, Honshu, Japan)", preserved in Zoologisches Institut und Zoologisches Museum der Universität Hamburg, not examined].

*Araneus ikomosanensis*: Saito 1939, P. 18.

*Suzumia orientalis* Kishida in Yuhara 1931, p. 150, fig. 75; Nakatsudi 1943b, p. 185, figs. 2F–H, 3A–E.

*Cyrtophora ikomosanensis*: Yaginuma 1958, p. 13, figs. 2A–E.

*Cyrtophora ikomasanensis* (sic): Yaginuma 1960, p. 65, fig. 158 in pl. 28 (excluding right lower figure), fig. 61 (in part); Yaginuma 1961, p. 24; Yaginuma 1962, p. 30; Yaginuma 1968a, p. 65, fig. 158 in pl. 28 (excluding right lower figure), fig. 61 (in part).

*Cyrtophora moluccensis*: Yaginuma 1968b, p. 36, figs. 1–2; Yaginuma 1986, p. 117, fig. 1 in pl. 32, fig. 62.1; Chikuni 1989, p. 81, fig. 53; Tanikawa 2003, pp. 11, 87, figs. 215a, 216 (in part); Tanikawa 2007, p. 43, figs. 11–15, 431–433; Tanikawa 2009, p. 423, figs. 20–22; Ogata 2009, pl.26, fig. 3.

*Specimens examined.* JAPAN. TOKYO. 1♀, Hachijō-jima Is., 20–VIII–2008, R. Mizusawa leg. KANAGAWA PREF. 1♀, Kōbō-yama, Hadano-shi, 15–IX–1989, AT leg. MIE PREF. 1♀3♂, 20–VIII–1980 (1♂: NSMT-Ar 8689), 1♀ 1♂, 11–VIII–1981 (NSMT-Ar 8690), Kokubu-chō, Suzukashi, A. Uyemura leg. 1♀, Arima-chō, Kumano-shi, 23–VIII–1993, AT leg. (NSMT-Ar 8691). 4♀, Kiwa-chō, Minamimuro-gun, 3–VIII–1991, AT leg. WAKAYAMA PREF. 1♀, Nachikatsuura-chō, Higashimuro-gun, 2–VIII–1991, AT leg. OKAYAMA PREF. 3♀, Higashitaichi, Tamano-shi, 26–VIII–1991, AT leg. 1♀, Okuichi, 25–VIII–1991, 1♀, Kamiachi, 25–VIII–1991, Okayama-shi, AT leg. EHIME PREF. 2♀1♂, Uchiko-chō, Kita-gun, 12–VIII–2004, AT leg. (1♀: NSMT-Ar 8692). FUKUOKA PREF. 1♀, Mt. Tachibanayama, Fukuoka-shi, 23–VIII–1991, AT leg. KUMAMOTO PREF. 1♀, Tategami-kyō, Yatsushiro-gun, 26–VIII–1981, AT leg. KAGOSHIMA PREF. 1♂, 24–VIII–1989 (NSMT-Ar 8693), 1♂, 17–VIII–1996 (NSMT-Ar 8694), 4♀, 14–IX–2005 (2♀: NSMT-Ar 8695–8696), 2♀, 9–IX–2007, AT leg. 1♂, 26–VII–2004, Y. Baba leg. (NSMT-Ar 8697). Amami-ōshima Is. 8♀, Kanemi, Tokunoshima Is., 12–IX–2007, AT leg. 3♀, Okinoerabu-jima Is., 7–IX–2007 (2♀: NSMT-Ar 8698–8699), AT leg. 1♀, Yoron-jima Is., 8–XI–2007, AT leg. OKINAWA PREF. 1♀, Okuma, Okinawa-jima Is., 12–XI–2005, AT leg. 1♀, Iheya-jima Is., 12–XI–2007, AT leg. 1♀, Komi, 20–VIII–1987, Iriomote-jima Is. TAIWAN. 1♀, Fushan, Ilan County, 10–VIII–2002, Y.-H. Chang leg. (THU-Ar 2010–005).

*Description.* Measurements. Based on 1♀ from Ehime (NSMT-Ar 8692) and 1♂ from Amami-ōshima Is. (NSMT-

Ar 8693), measurements in parentheses indicate the range among specimens, ♀/♂, in mm. Body 15.88 (11.25–19.88)/4.38 (3.95–4.67) long. Carapace 6.27 (5.06–8.00)/2.13 (1.88–2.25) long; 4.87 (3.88–6.08)/1.73 (1.56–1.74) wide. Length of legs [tarsus + metatarsus + tibia + patella + femur = total]: I, 2.20 + 7.40 + 6.45 + 2.90 + 8.60 = 27.55/1.00 + 2.31 + 2.14 + 0.90 + 2.69 = 9.04; II, 2.10 + 6.60 + 5.60 + 2.80 + 8.20 = 25.30/0.94 + 2.03 + 1.80 + 0.86 + 2.49 = 8.12; III, 1.40 + 3.90 + 3.00 + 2.10 + 5.20 = 15.60/0.63 + 1.11 + 0.86 + 0.60 + 1.49 = 4.69; IV, 1.70 + 6.45 + 4.90 + 2.80 + 7.80 = 23.65/0.77 + 1.83 + 1.46 + 0.77 + 2.29 = 7.12. Abdomen 12.38 (7.25–12.75)/2.66 (2.43–2.71) long, 6.75 (4.83–9.75)/1.71 (1.66–1.83) wide.

Female and male. Carapace longer than wide [length/width 1.29 (1.27–1.32)/1.23 (1.21–1.29)]. MOA longer than wide in female [length/width 1.15 (1.07–1.20)], almost as long as wide in male [length/width 0.75 (0.75–1.03)], anterior width and posterior width almost same in female [anterior width/posterior width 1.07 (1.04–1.11)], wider in front than behind in male [anterior width/posterior width 1.58 (1.20–1.58)]. Fung furrow of chelicera with 4 (3–4) promarginal and 3 (3–4)/3 (2–3) retromarginal teeth. Labium wider than long [length/width 0.69 (0.61–0.72)/0.64 (0.52–0.68)]. Sternum slightly longer than wide [length/width 1.15 (1.13–1.21)/1.05 (1.05–1.13)]. Length of leg I/length of carapace 4.39 (4.33–4.41)/4.24 (4.14–4.42). Median apophysis of male palp thick (Fig. 17, arrow). Abdomen longer than wide [length/width 1.83 (1.31–1.83)/1.55 (1.39–1.55)], anteriorly with a pair of tubercles (Figs. 3, 21–25). Female genitalia: median septum almost straight in lateral view (Figs. 14–16).

Coloration and markings. Female. Carapace dark brown with many white pubescence. Abdomen varied; reddish brown or greenish brown mottled with white, bright orange, dark wine red, or pale brown without markings. Male. Carapace light brown laterally with dark brown marking, abdomen pale brown mottled with white.

*Distribution.* Japan (Honshu, Shikoku, Kyushu, Nansei Isls.), Taiwan.

*Remarks.* *Cyrtophora ikomosanensis* closely resembles *C. moluccensis*. For the discriminating point between these species, see the remarks of the latter.

*Notes.* Although *C. ikomosanensis* was synonymized with *C. moluccensis* by Yaginuma (1968b), here it is resurrected from the synonymy.

#### Acknowledgment

We wish to express our heartfelt thanks to Dr. Tadashi Miyashita, the University of Tokyo, for his critical reading of the manuscript of this paper. We are deeply indebted to Dr. Erik J. van Nieuwerkerken, National Museum of Natural History Naturalis, Leiden, Dr. Jürgen Gruber, Naturhistorische Museum, Wien, for their loaning invaluable specimens. Our hearty thanks are also due to Dr. Yuki G. Baba, Ibaraki, Mr. Tomoyuki Kimura, Tokyo, Ms. Haruko Nakajima, Tokyo, Mr. Ryuta Nakajo, Saitama, Dr. Masakata Nishimura, Tokyo, Mr. Kiyoto Ogata, Aichi, Ms. Booppa Ponksee, Thailand, Mr. Akiya Uyemura, Mie, for their offering useful specimens used in this paper.

## References

- Bösenberg, W. & Strand, E. 1906. Japanische Spinnen. Abh. Senck. Naturf. Ges., 30: 93–422.
- Chen, S.-H. 2001. A Guide to Common Spiders of Taiwan. Committee of Agriculture, Executive Branch of Taiwan, Taipei, 317 pp. (In Chinese)
- Chikuni, Y. 1989. Pictorial Encyclopedia of Spiders in Japan. Kaiseisha Publishing, Tokyo, 309 pp. (In Japanese)
- Chrysanthus, P. 1959. Spiders from south New Guinea II. Nova Guinea (N.S.), 10: 197–206.
- Chrysanthus, P. 1960. Spiders from south New Guinea III. Nova Guinea (N.S.), 10: 23–42.
- Chrysanthus, P. 1971. Further notes on the spiders of New Guinea I (Argyropidae). Zool. Verh. Leiden, 113: 1–52.
- Davies, V. T. 1988. An illustrated guide to the genera of orb-weaving spiders in Australia. Mem. Qd Mus., 25: 273–332.
- Doleschall, L. 1857. Bijdrage tot de Kennis der Arachniden van den Indischen Archipel. Nat. Tijdschr. Neder.-Ind., 13: 339–434.
- Kayashima, I. 1943. Spiders of Taiwan. Tôto-Shoseki Publishing, Tokyo, 65 pp. (In Japanese)
- Keyserling, E. 1865. Beiträge zur Kenntniss der Orbitelae Latr. Verh. Zool.-Bot. Ges. Wien, 15: 799–856.
- Koch, L. 1871. Die Arachniden Australiens, nach der Natur beschrieben und abgebildet. Nürnberg, 1: 1–104.
- Koh, J. K. H. 1991. Spiders of the family Araneidae in Singapore mangroves. Raffles Bull. Zool., 39: 169–182.
- Kulczyński, W. 1910. Araneae et Arachnoidea Arthrogastra. In: Botanische und zoologische Ergebnisse einer wissenschaftlichen Forschungsreise nach den Samoainseln, dem Neuguinea-Archipel und den Solomon inseln von März bis Dezember 1905 von Dr Karl Reehinger. III Teil. Denkschr. Akad. Wiss. Wien, 85: 389–411.
- Li, W., Fu, Y., & Tso, I. 2002. Field Guide 1. Spiders. Qinqin Cultural Program Ltd. Co., Taipei, 264 pp. (In Chinese)
- Nakatsudi, K. 1943a. Some Arachnida from Micronesia. J. Agric. Sci. Tokyo (Nogyo Daigaku), 2: 147–180.
- Nakatsudi, K. 1943b. Some Arachnida from Is. Okinawa and Is. Amami-Osima. J. Agric. Sci. Tokyo Nogyo Daigaku, 2: 181–194.
- Ogata, K. 2009. *Cyrtophora moluccensis*. (Fig. 3 in p. 622 only). In: Ono, H. (ed.) The Spiders of Japan with Keys to the Families and Genera and Illustrations of the Species. Tokai University Press, Kanagawa, 738 pp. (In Japanese)
- Platnick, N. I. 2009. The world spider catalog, version 10.0. American Museum of Natural History, online at <http://research.amnh.org/entomology/spiders/catalog/index.html>
- Pocock, R. I. 1897. Spinnen (Araneae). In: Kukenthal, Ergebnisse einer zoologische Forschungsreise in dem Molukken und Borneo. Abh. Senckenb. Naturf. Ges., 23: 591–629.
- Pocock, R. I. 1898. Scorpions, Pedipalpi and spiders from the Solomon Islands. Ann. Mag. Nat. Hist., (7)1: 457–475.
- Rainbow, W. J. 1898. Contribution to a knowledge of the arachnid fauna of British New Guinea. Proc. Linn. Soc. New S. Wales, 23: 328–356.
- Saito, S. 1939. On the spiders from Tohoku (northernmost part of the main island), Japan. Saito Ho-on Kai Mus. Res. Bull. 18: 1–91.
- Simon, E. 1895. Histoire naturelle des araignées. Paris, 1: 761–1084.
- Song, D. X., Zhu, M. S. & Chen, J. 1999. The Spiders of China. Hebei Sci. Technol. Publ. House, Shijiazhuang, 640 pp.
- Tanikawa, A. 2003. Spiders in Okinawa. Bunyô-sha, Tokyo, 95 pp. (In Japanese)
- Tanikawa, A. 2007. An Identification Guide to the Japanese Spiders of the Families Araneidae, Nephilidae and Tetragnathidae. Arachnological Society of Japan, Osaka, 121 pp. (In Japanese)
- Tanikawa, A. 2009. Araneidae. pp. 420–463. In: Ono, H. (ed.) The Spiders of Japan with Keys to the Families and Genera and Illustrations of the Species. Tokai University Press, Kanagawa, 738 pp. (In Japanese)
- Tanikawa, A. & Miyashita, T. 2008. A revision of Japanese spiders of the genus *Dolomedes* (Araneae: Pisauridae) with its phylogeny based of mt-DNA. Acta Arachnol., 57: 19–35.
- Tamura, K., Dudley, J., Nei, M. & Kumar, S. 2007. MEGA4: Molecular Evolutionary Genetics Analysis (MEGA) software version 4.0. Molecular Biology and Evolution, 24: 1596–1599. (Publication PDF at <http://www.kumarlab.net/publications>)
- Thompson, J. D., Higgins, D. G. and Gibson, T. J. 1994. CLUSTAL W: improving the sensitivity of progressive multiple sequence alignment through sequence weighting, position specific gap penalties and weight matrix choice. Nucleic Acids Research, submitted, June 1994.
- Tikader, B. K. 1982. Family Araneidae (=Argiopidae), typical orbweavers. Fauna India (Araneae), 2: 1–293.
- Walckenaer, C. A. 1842. Histoire naturelle des Insectes. Aptères. Paris, 2: 1–549.
- Yaginuma, T. 1958. Revision of Japanese spiders of family Argiopidae. II. Genus *Cyrtophora*. Acta Arachnol., 16: 10–17. (In Japanese)
- Yaginuma, T. 1960. Spiders of Japan in Colour. Hoikusha Publishing, Osaka, 186 pp. (in Japanese)
- Yaginuma, T. 1961. Revision of Families, Genera and Species of Japanese Spiders. Arachnological Society of East Asia (Osaka), 45 pp. (In Japanese)
- Yaginuma, T. 1962. The Spider fauna of Japan. Arachnological Society of East Asia, 1–74+2 plates+18 pp.
- Yaginuma, T. 1968a. Spiders of Japan in Colour. Enlarged and Revised Edition. Hoikusha Publishing, Osaka, 197 pp. (In Japanese)
- Yaginuma, T. 1968b. The spider genus *Cyrtophora* of Japan. Kansaishizenkagaku (Kansai Natural Sciences), No. 20, pp. 34–38. (In Japanese with English summary)
- Yaginuma, T. 1986. Spiders of Japan in Color. New Edition. Hoikusha Publishing, Osaka, 305 pp. (In Japanese)
- Yin, C. M., Wang, J. F., Xie, L. P. & Peng, X. J. 1990. New and newly recorded species of the spiders of family Araneidae from China (Arachnida, Araneae). In: Spiders in China: One Hundred New and Newly Recorded Species of the Families Araneidae and Agelenidae. Hunan Normal Univ. Press, 171 pp.
- Yin, C. M., Wang, J. F., Zhu, M. S., Xie, L. P., Peng, X. J. & Bao, Y. H. 1997. Fauna Sinica: Arachnida: Araneae: Araneidae. Science Press, Beijing, xiii+460 pp.
- Yuhara, S. 1931. A Study of Spiders. Sôgô-Kagaku Publishing (Tokyo) 305 pp. (In Japanese)

Received February 18, 2010 / Accepted April 10, 2010